

## **5 Belt Cleaners**

## 5 Belt cleaners

<b>Summary</b>	<b>5</b>	<b>Belt cleaners and scrapers</b>	<b>pag. 257</b>
<b>5.1</b>		<b>Introduction.....</b>	<b>259</b>
<b>5.2</b>		<b>Selection criteria.....</b>	<b>260</b>
<b>5.3</b>		<b>Programme of belt cleaners with blades made.....</b>	<b>261</b>
		<b>of tungsten-carbide</b>	
5.3.1		Belt cleaners type-P .....	262
5.3.2		Belt cleaners type-R .....	264
5.3.3		Belt cleaners type-H .....	266
5.3.4		Belt cleaners type-D .....	268
5.3.5		Belt cleaners simple and plough types .....	270
<b>5.4</b>		<b>Scrapers with Polyurethane blades .....</b>	<b>272</b>
5.4.1		Scrapers with Polyurethane blades - Guide Table .....	273
5.4.2		Scraper PU 83 .....	274
5.4.3		Scraper PU 29 .....	275
5.4.4		Scraper PU 89 .....	276
5.4.5		Scraper PU 91 .....	277
5.4.6		Secondday scraper PU 92.....	278
5.4.7		Plough scraper PU 88.....	279
5.4.8		Codes PU Series - Polyurethane Scrapers .....	280
5.4.9		Codes SPU Spare Parts & Accessories - PU Series Scrapers ...	282



## 5.1 - Introduction

The problem of conveyed material adhering to the conveyor belt occurs frequently with wet or sticky material, resulting in frequent downtime for maintenance and clean up, with consequent loss of production.

The problems of belt cleaning have increased in parallel with the development of conveyors of ever increasing lengths, speed and belts widths, necessary to satisfy the need to maximise load capacities.

Therefore, the use of cleaning equipment has become an indispensable requirement to assure general plant efficiency and to reduce the periods of service needed for maintenance.

There has been a notable development of this equipment in recent time for differing reasons: prolonging the life of the conveyor, limiting the deterioration of the belt, improving the energy efficiency of the installation, reducing loss of material thereby increasing the load capacity, eliminating a major cause of wear on the return rollers.

Our standard product range is composed by:

- belt cleaners with blades made of tungsten-carbide;
- scrapers with Polyurethane blades.



## 5 Belt cleaners



### 5.2 - Selection criteria

The choice of a belt cleaner depends on the efficiency that is desired to obtain from the conveyor, the material itself and the environmental conditions prevailing.

However the adoption of a cleaning system should be considered early in the conveyor project design phase.

It may prove to be very difficult to achieve an average degree of efficiency by retrofitting cleaning system into an existing plant; moreover, this operation may necessitate expensive modification to the plant structure.

Where high standard of cleaning is requested, and for particularly difficult applications, it is advisable to employ more than one cleaning system combining them in a way that increases the overall system efficiency.

It is however good practice that the user scrupulously observes the function and maintenance of the cleaners in use, to assure their maximum and continuous efficiency.

The belt cleaners proposed in this catalogue may be used for each type of application. They are well known for their efficiency, for ease of installation, for their project simplicity and economy of use.

There may be irregularities on the belt surface, such as metal clips, removed or lacerated sections of parts of the belt cover layers this may create abnormal wear in the components of the chosen scraper and lead to even further irregularities as mentioned above.

In this catalogue several different cleaners are proposed.

On request other types may be supplied other than the standard to facilitate installation and to extend the use for special applications.

### 5.3 - Programme of belt cleaners with blades made of tungsten-carbide

Cleaner type	For belt width mm	Characteristics
<b>P</b>	350 ÷ 2200	For single directional belts
<b>R</b>	350 ÷ 2200	For reversible belts
<b>H</b>	350 ÷ 2200	For reversible belts and tangential applications
<b>D</b>	350 ÷ 2200	For single directional belts

On request belt widths larger than those indicated or for special applications may be supplied.

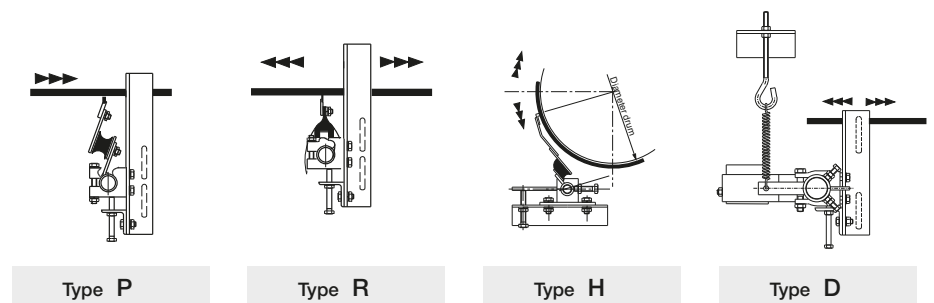

## 5 Belt cleaners

### series P



#### 5.3.1 - Belt cleaners series P for single directional belts

The proposed cleaner is a blade of multiple scrapers mounted on an intermediate flexible support which allows the blade an independent movement and assures a continuous and efficient cleaning of the belt.

They are principally applied to the removal of wet or sticky material in belts with a single movement direction.

##### Characteristics and indications of use

The cleaners, series P, are characterised by scraper components (TIPS) attached to flexible and very resistant rubber components mounted onto a tubular frame.

These supports, which act as anchors for the scrapers, give the correct balance between the frictional force and the necessary force needed to remove the residual scale on the belt surface.

For its correct function the pressure of blade application is very low. It is however possible to control it by changing the position of an opposing screw from the moveable support onto the support frame.

These cleaners, especially because of their simplicity of construction, may be installed very easily with extremely controlled service and maintenance costs.

The excellent quality of the material used and the strength of the components, sized to meet overload conditions, lead to an assurance of prolonged and efficient life.

In addition to the standard types, special versions may be supplied for food or chemical environments.

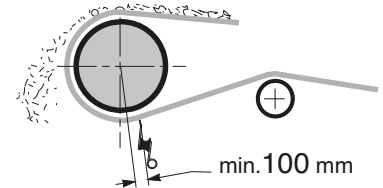

- 1 - Blade
- 2 - Rubber cushion
- 3 - Frame
- 4 - Clamp
- 5 - Bracket
- 6 - Adjusting bolt
- 7 - Deflector

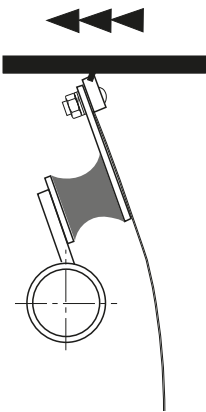
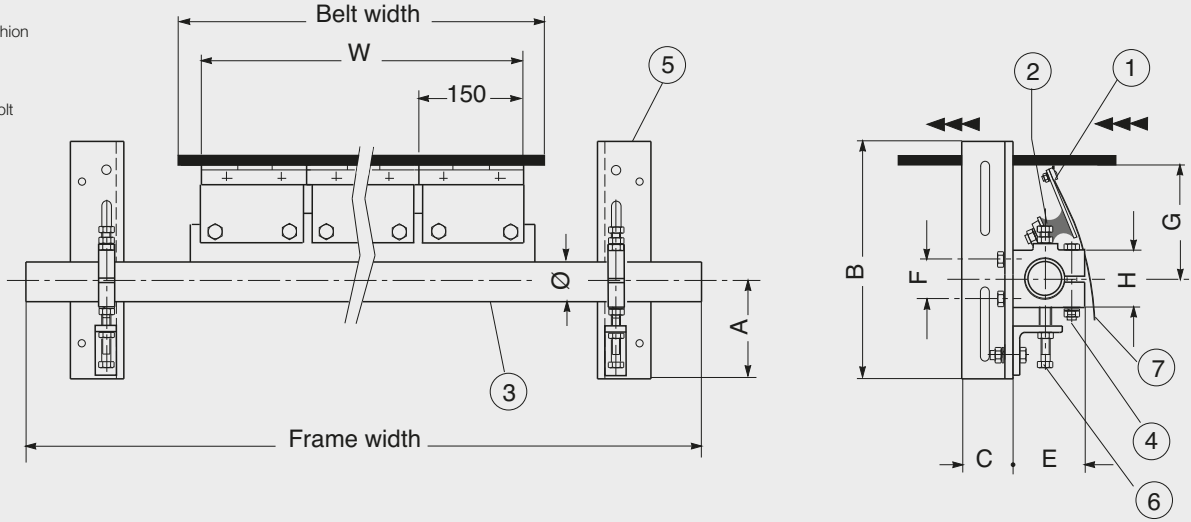

Belt cleaner type	Belt width mm	Tips n.	W mm	Frame width mm	A		B	C	Ø	E	F	G	H	Weight Kg
					min.	max.								
P	300/400	2	300	900										20
	450/500	3	450	1050										25
	600/650	4	600	1200										30
	750/800	5	750	1350										35
	900/1000	6	900	1550	120	200	320	70	54.0	85	56	154	80	40
	1050	7	1050	1700										44
	1200	8	1200	1900										48
	1400	9	1350	2100										54
	1500/1600	10	1500	2350										62
	1800	12	1800	2600										75
	2000	13	1950	2800	152	232	400	80	76.3	115	70	165	105	100
	2200	14	2100	3100										110

On request different dimensions to W as indicated may be supplied.

Example of ordering  
Cleaner type P, 800

## 5 Belt cleaners

### series R

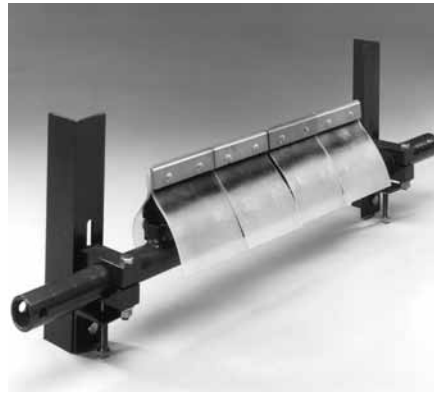

#### 5.3.2 - Belts cleaners series R for reversible belts

This type of cleaner has been developed to function with reversible belts.

Its arrangement of multiple scraper blades of straight forward construction is unique of its type, resulting in excellent efficiency.

##### Characteristics and indication of use

The characteristics of the cleaner series R is also that it uses a tubular member, with scraper blade components positioned on its structure and fixed between intermediate rubber supports as in the series P.

The rubber components are cleverly profiled and allow the application of the scraper blades on both senses of rotation Fig. A.

The blade may then flex in both directions without damaging or promoting damage to the belt in case of unforeseen pressures.

The scraper blade is positioned perpendicular to the belt which is different to that of the position of belt cleaner P.

The most important factors for the efficient system function are the correct installation and the precise regulation of the belt cleaner.

These instructions are described in a related booklet attached to the cleaner itself on delivery.

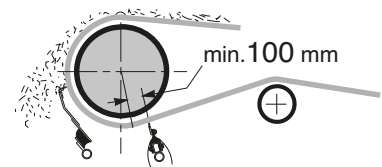

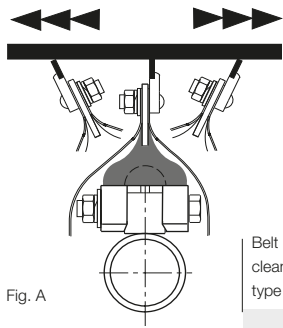
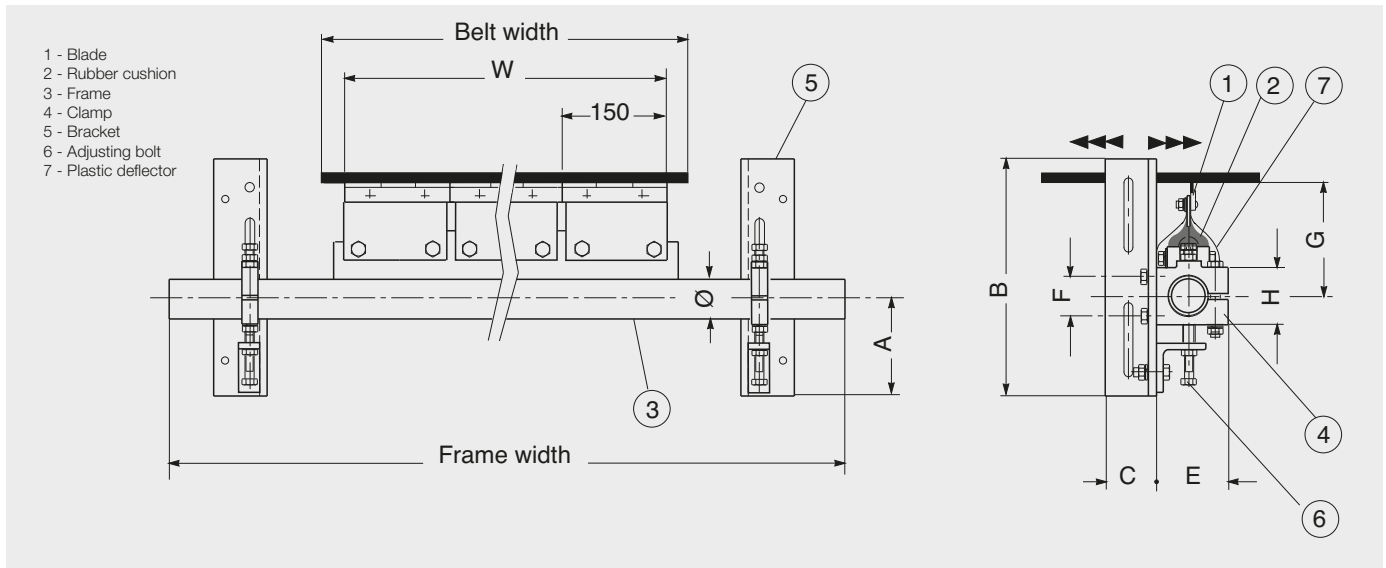

Belt cleaner type	Belt width mm	Tips n.	W mm	Frame width mm	A		B	C	Ø	E	F	G	H	Weight Kg
					min.	max.								
R	300/400	2	300	900										20
	450/500	3	450	1050										25
	600/650	4	600	1200										30
	750/800	5	750	1350										35
	900/1000	6	900	1550	120	200	320	70	54.0	85	56	145	80	40
	1050	7	1050	1700										44
	1200	8	1200	1900										48
	1400	9	1350	2100										54
	1500/1600	10	1500	2350										62
	1800	12	1800	2600										75
	2000	13	1950	2800	152	232	400	80	76.3	115	70	156	105	100
	2200	14	2100	3100										110

On request different dimensions to W as indicated may be supplied.

Example of ordering  
Cleaner type R, 1200

## 5 Belt cleaners

### series H



#### 5.3.3 - Belt cleaners series H for reversible and single directional belts for tangential applications

This cleaning device has been developed principally as a scraper, capable of removing the majority of residual material from the belt surface.

The complete system of cleaning the belt may be made by utilising successive cleaners, chosen for example, from the range in series P or R.

May be installed where it is not always possible to install other types.

#### Characteristics and indications of use

The belt cleaner series H, has similar characteristics to the preceding series, in using a tubular member. The multiple scraper blades are positioned on this structure and themselves fixed by means of supporting arms proportional in size to the diameter of the drum and anchored finally in rubber supports.

The construction characteristic of the system, allows in this case the use of extremely low functional pressure, precisely controlled by means of an appropriate regulating screw.

The belt cleaner employs a tangential action and is therefore applied to the external front part of the pulley.

It is then engaged in the task of cleaning the belt on the pulley using a perpendicular or square application.

The simplicity of design of this series assures excellent function over time and economies are found both in management costs and the consequent reduction of labour costs involved in maintenance.

May be easily installed on the belt conveyor structure, reversible, to suit extendible and other types of conveyors.

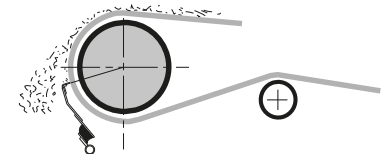

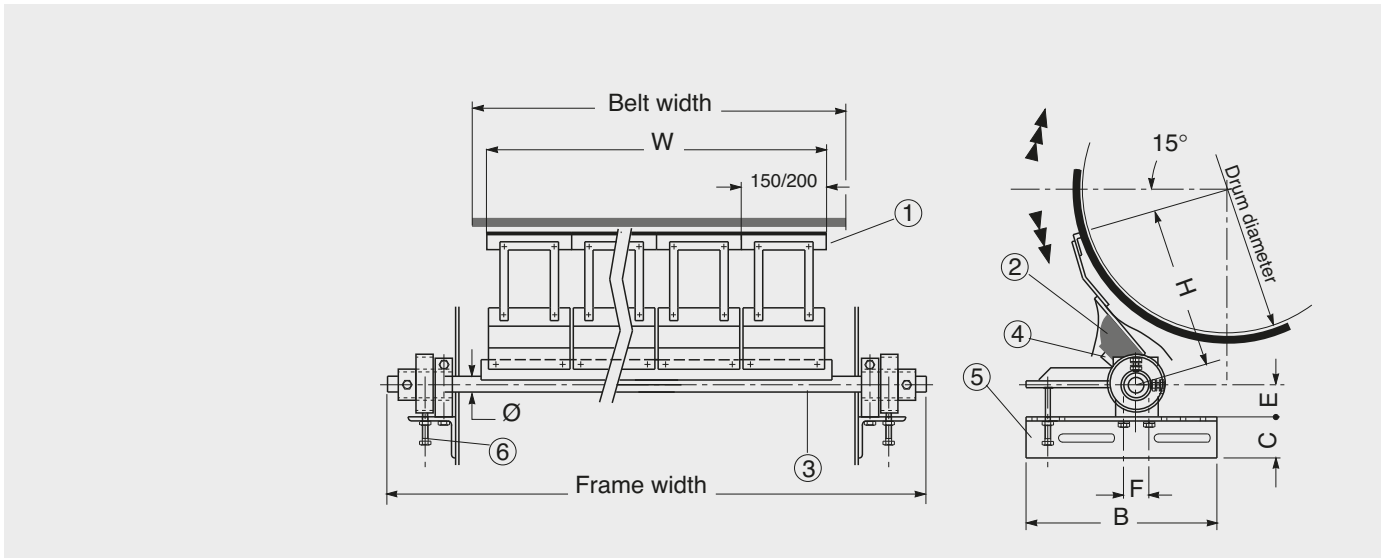

- 1 - Scraper tips
- 2 - Rubber cushion
- 3 - Frame
- 4 - Clamp
- 5 - Support
- 6 - Regulating screw

Belt cleaner type	Belt width mm	Tips		W mm	Frame width mm	B	F	C	Ø	E	Weight Kg
		mm	n.								
H	300/400	150	2	300	1000	320	56	70	54.0	60	23
H	450/500	150	3	450	1000	320	56	70	54.0	60	25
H	600/750	200	3	600	1300	320	56	70	54.0	60	30
H	800/900	200	4	800	1500	320	56	70	54.0	60	35
H	1000/1050	200	5	1000	1650	320	56	70	54.0	60	45
H	1200	200	6	1200	1900	320	56	70	54.0	60	60
H	1400/1500	200	7	1400	2150	320	56	70	54.0	60	75
H	1600	200	8	1600	2300	320	56	70	54.0	60	90
H	1800	200	9	1800	2600	400	70	80	76.3	70	105
H	2000	200	10	2000	3000	400	70	80	76.3	70	120
H	2200	200	11	2200	3200	400	70	80	76.3	70	135

On request different dimensions to W as indicated may be supplied.

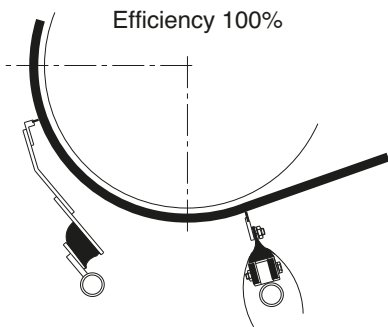

To order belt cleaners series H it is necessary to complete the type code with a model code which relates to the diameter of the pulley using the following table.

Cleaner type	model	Pulley Ø mm	H mm ~
H	SS	less than 500	276
H	S	500 ÷ 800	333
H	M	700 ÷ 1100	384
H	L	1000 ÷ 1200	416
H	LL	greater than 1200	527

Example of ordering  
Cleaner type HS, 1000

## 5 Belt cleaners

### series D

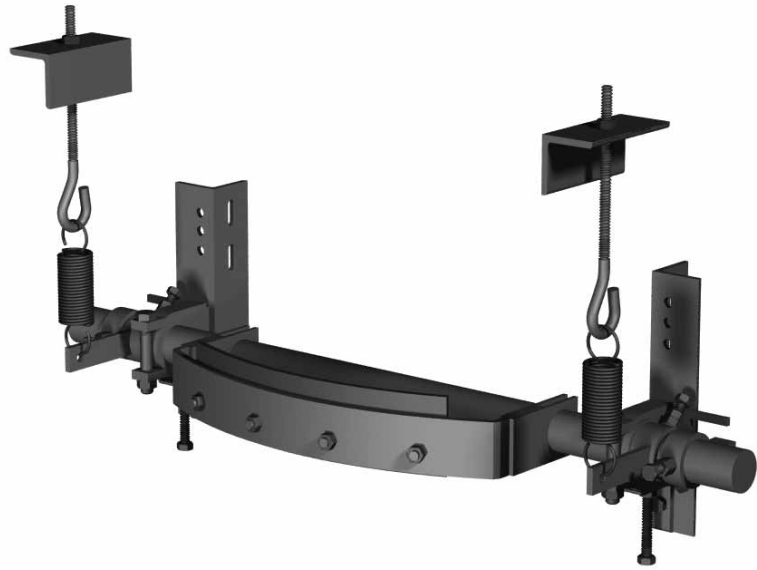

#### 5.3.4 - Belt cleaners series D patented for single directional belts

Awareness of improved savings by utilizing belt cleaning systems has resulted in requests for simplified equipment but with ever increasing efficiency.

The conception of this proposed cleaner is certainly revolutionary.

##### Characteristics and indications of use

The cleaner type D is characteristic of a new technology.

It consists of a carbon steel blade, welded to a curved support. The assembly constitutes a unique scraper blade, inserted into a strong structural arc mounted on special bearings.

Although there is vertical adjusting, the system is under spring pressure which acts to rotate the curved structure as a whole. The pressure of the blade is therefore stronger at the centre. The pressure is however controlled by a regulating screw.

The cleaning effect is therefore correspondingly higher in the central part, where there is normally the most residue of material to remove, and becomes less as it decreases towards the edge.

In this way the scraper is acting at its most efficient where the areas of high wear are normally encountered on the blade and the belt.

Thanks to the scraper and unique blade being formed into an arc the material that is removed has no tendency to build up or to block the cleaning action itself.

The scraper blade is the only replaceable component that will exhibit wear in time. It is easily and rapidly replaced without further disassembly of the scraper in situ.

This type of universal belt cleaner is particularly recommended to be used on high speed single directional conveyor belts, when the conveyed material is very wet and sticky.

Even greater belt cleaning performance may be obtained by using this cleaner linked with cleaner series H.

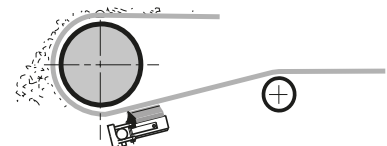

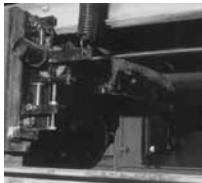
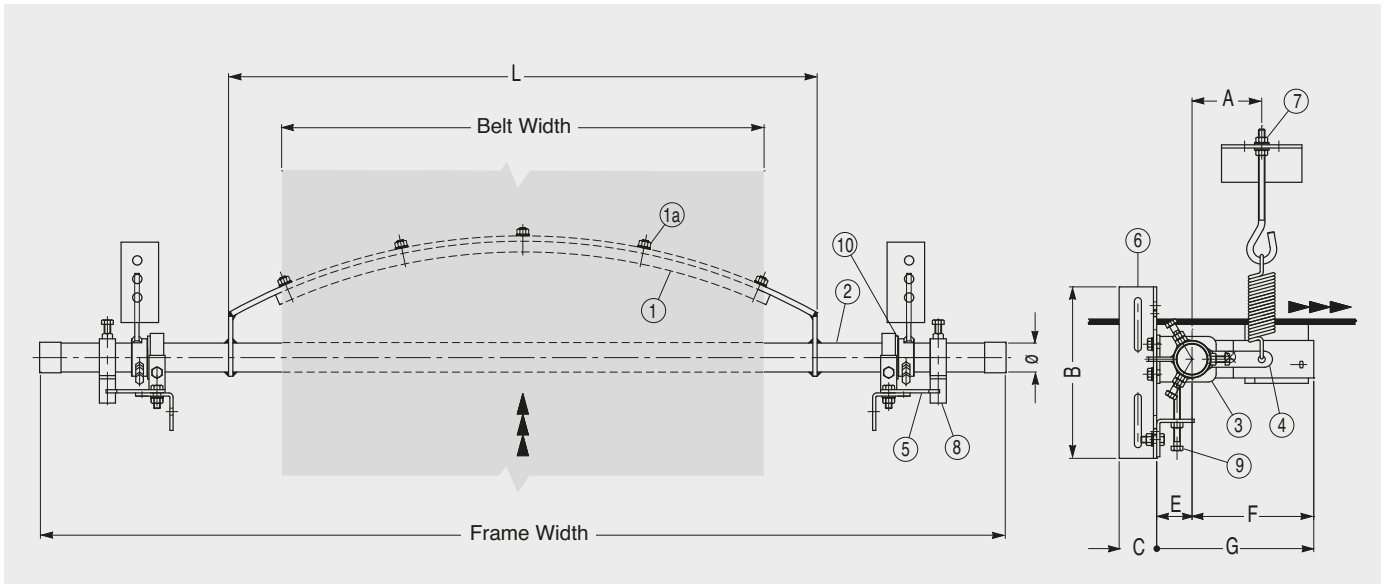

- 1 - Blade
- 1a - Blade fixing screws
- 2 - Frame
- 3 - Clamp
- 4 - Spring tensioning system
- 5 - Rotation stopper plate
- 6 - Bracket
- 7 - Pressure adjustment
- 8 - Rotation stopper
- 9 - Height adjustment screw
- 10 - Rotation bush

Belt cleaner type	Belt width mm	Frame width mm	L	A	B	C	Ø	E	F	G	Peso Kg
<b>D</b>	<b>400</b>	<b>1000</b>	<b>490</b>	<b>130</b>	<b>320</b>	<b>70</b>	<b>54</b>	<b>66</b>	<b>141</b>	<b>207</b>	<b>20</b>
	<b>450</b>	<b>1100</b>	<b>540</b>	<b>130</b>	<b>320</b>	<b>70</b>	<b>54</b>	<b>66</b>	<b>146</b>	<b>212</b>	<b>25</b>
	<b>500</b>	<b>1200</b>	<b>590</b>	<b>130</b>	<b>320</b>	<b>70</b>	<b>54</b>	<b>66</b>	<b>152</b>	<b>218</b>	<b>30</b>
	<b>600</b>	<b>1300</b>	<b>690</b>	<b>130</b>	<b>320</b>	<b>70</b>	<b>54</b>	<b>66</b>	<b>164</b>	<b>230</b>	<b>40</b>
	<b>650</b>	<b>1350</b>	<b>740</b>	<b>130</b>	<b>320</b>	<b>70</b>	<b>54</b>	<b>66</b>	<b>179</b>	<b>245</b>	<b>42</b>
	<b>750</b>	<b>1500</b>	<b>840</b>	<b>130</b>	<b>320</b>	<b>70</b>	<b>54</b>	<b>66</b>	<b>182</b>	<b>248</b>	<b>45</b>
	<b>800</b>	<b>1550</b>	<b>890</b>	<b>130</b>	<b>320</b>	<b>70</b>	<b>54</b>	<b>66</b>	<b>194</b>	<b>260</b>	<b>50</b>
	<b>900</b>	<b>1700</b>	<b>990</b>	<b>130</b>	<b>320</b>	<b>70</b>	<b>54</b>	<b>66</b>	<b>200</b>	<b>266</b>	<b>55</b>
	<b>1000</b>	<b>1800</b>	<b>1090</b>	<b>130</b>	<b>320</b>	<b>70</b>	<b>54</b>	<b>66</b>	<b>213</b>	<b>279</b>	<b>60</b>
	<b>1200</b>	<b>2100</b>	<b>1290</b>	<b>130</b>	<b>320</b>	<b>70</b>	<b>54</b>	<b>66</b>	<b>237</b>	<b>303</b>	<b>65</b>
	<b>1400</b>	<b>2300</b>	<b>1490</b>	<b>130</b>	<b>320</b>	<b>70</b>	<b>54</b>	<b>66</b>	<b>270</b>	<b>336</b>	<b>75</b>
	<b>1500</b>	<b>2400</b>	<b>1590</b>	<b>130</b>	<b>320</b>	<b>70</b>	<b>54</b>	<b>66</b>	<b>253</b>	<b>319</b>	<b>80</b>
	<b>1600</b>	<b>2500</b>	<b>1690</b>	<b>130</b>	<b>320</b>	<b>70</b>	<b>54</b>	<b>66</b>	<b>256</b>	<b>322</b>	<b>85</b>
<b>1800</b>	<b>2700</b>	<b>1890</b>	<b>160</b>	<b>400</b>	<b>70</b>	<b>76</b>	<b>80</b>	<b>250</b>	<b>328</b>	<b>95</b>	
<b>2000</b>	<b>3100</b>	<b>2090</b>	<b>160</b>	<b>400</b>	<b>70</b>	<b>76</b>	<b>80</b>	<b>250</b>	<b>328</b>	<b>105</b>	
<b>2200</b>	<b>3300</b>	<b>2290</b>	<b>160</b>	<b>400</b>	<b>70</b>	<b>76</b>	<b>80</b>	<b>250</b>	<b>328</b>	<b>115</b>	

Example of ordering  
Cleaner type D, 1400

## 5 Belt cleaners

### series **PLG** **VLG - VLP**

#### 5.3.5 - Belt cleaners simple and plough types

The most economic of cleaners with a scraper made of anti-abrasive rubber. The cleaners are applicable to light belts where the economies in the working conditions are of fundamental importance. Proposed therefore for belt widths from 400 up to 1200 mm.

##### Simple belt cleaner type PLG

Comprises a steel structure in which is positioned a blade of anti-abrasive rubber (60 shore) of thickness 15 mm. Considering the effect of pressure exercised on the belt, this cleaner should be supplied at the time of conveyor installation.



The cleaner PLG is for belt widths of 400, 500 and 650 mm. To be installed near to the drive drum.

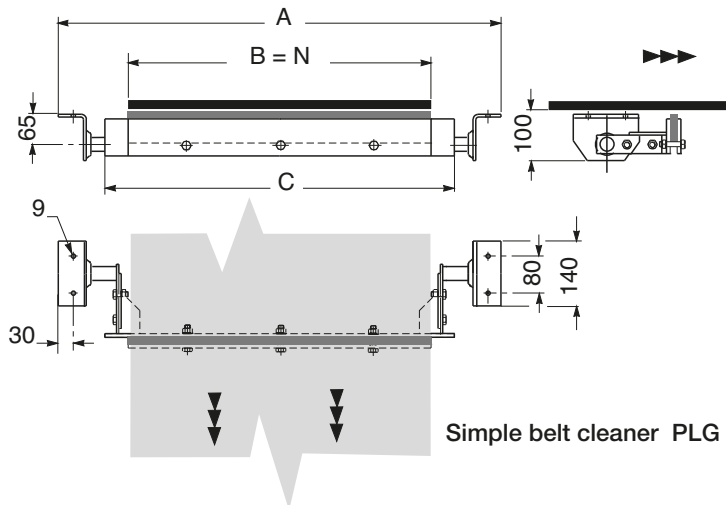

Simple belt cleaner PLG

Belt width mm	A	B	C
400	700	400	500
500	800	500	600
650	950	650	750

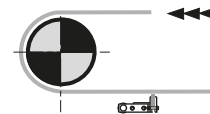

Example of ordering  
Cleaner type PLG, 400

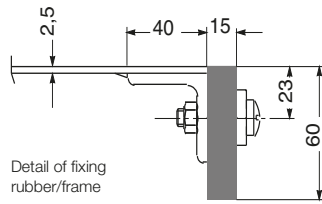

Plough cleaner type VLG

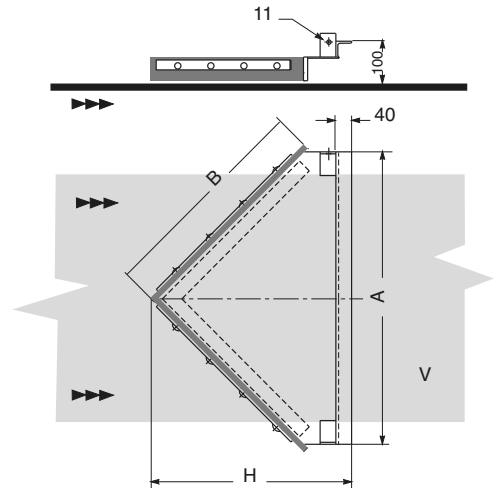
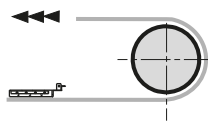

Belt width mm	A	B	H
400	500	350	360
500	600	420	410
650	740	525	480

**Belt plough cleaner type VLG - VLP**

This is a system applied to the internal side of the return belt adjacent to the return drum.

Any residual material is deviated and removed by the effective action effect of the "V" design just before it reaches the belt terminal drum.

The plough, standard model type VLG, and the pressure regulating version type VLP for heavy applications meet direct customer needs for specific uses.

The belt plough cleaner must be installed at the terminal end to the belt near to the return drum, with the plough positioned in the opposite sense to the direction of movement of the belt.

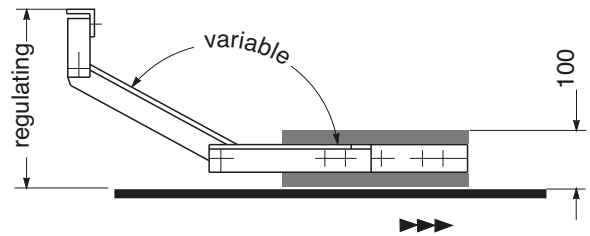

Belt width mm	A	B	H
800	1100	600	850
1000	1300	750	1060
1200	1550	890	1260
1400	1750	1030	1460
1600	1950	1170	1660

Plough cleaner type VLP

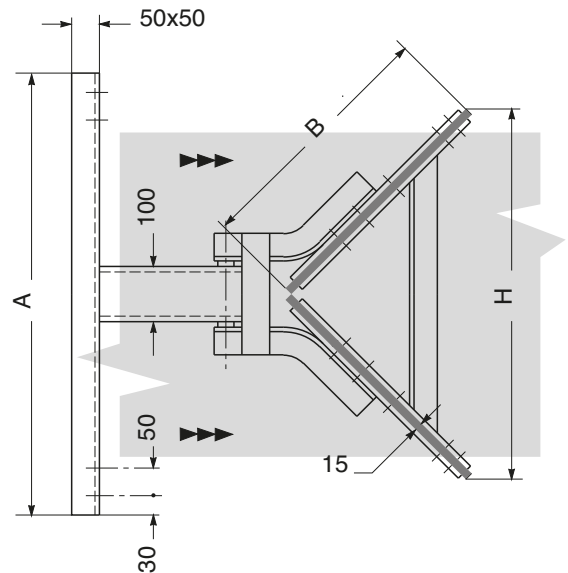
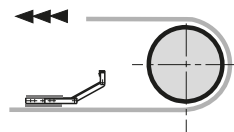

Example of ordering  
Cleaner type VLG, 500  
VLP, 650

## 5 Belt Scrapers

### Scrapers with Polyurethane blades

- Type PU-83 Simple Pre-scraper with single polyurethane blade**  
Position: Tangential for pulleys Ø 220-1000 mm.  
For BW 400-2000, max speed 3.5m/s, also reversible.  
For easy to medium cleaning. Typically a first scraper for an end user  
Also used by many OEM as a standard scraper.  
Easy to replace the scraper blade without tools.  
The scraper must not be fitted to chevron belts or belts with mechanical joints.  
For materials: Sand, Gravel, Stone, Saw dust, garbage, soil.
- Type PU-29 Pre-scraper with single polyurethane blade**  
Position: Tangential for pulleys Ø 320-800 mm  
For BW 400-1600. (B-W 1000 the scraper is supplied with dual lever arms, B-W 1600 the scraper is supplied with Holder HD), max speed 5,0 m/s, also reversible.  
Design is patented.  
Easy to service and maintain. Easy to replace the scraper blade without tools.  
All steel parts are electro- galvanized as standard.  
For materials: Gravel, limestone, crushed stone, iron ore, cement.
- Type PU-89 Heavy Pre- scraper single strong and thick polyurethane blade**  
Position: Tangential for big pulleys Ø 400-1000 mm.  
For BW 650-1600, max speed 6 m/s, also reversible.  
For heavy cleaning. Easy to replace the scraper blade without tools.  
The scraper must not be fitted to chevron belts or belts with mechanical joints.  
For materials: Gravel, limestone, crushed stone, iron ore, cement.
- Type PU-91 Pre- scraper with segment polyurethane blades**  
Position: Tangential for pulleys Ø 200-630 mm.  
For BW 400-2000, max speed 3.5\* m/s, also reversible.  
Medium to heavy cleaning. Accurate cleaning due to flexible multi sectored blades.  
Easy to service and maintain.  
The scraper must not be fitted to chevron belts or belts with mechanical joints.  
For materials: Sand, Gravel, crushed stone, wet and sticky material.
- Type PU-92 Secondary scraper**  
Single strong and thick polyurethane blade and pre-tensioning device.  
Position: under the return belt 30-100 mm away from the head pulley.  
For BW 400-2000, max speed 3.5\*\* m/s, single direction belts.  
For medium industry with stringent cleaning requirements.  
Also in combination with a pre-scraper for a max cleaning effect.  
Easy to service and maintain. Can be fitted with tungsten-carbide blades.  
The scraper must not be fitted to chevron belts or belts with mechanical joints.  
For materials: Gravel, limestone, crushed stone, iron ore, cement and others.
- Type PU-88 Plough scraper**  
Self aligning steel frame and 2 exchangeable PU-scraper strips.  
Position: on the return belt before the tail pulley.  
For BW 400-1800, max speed 4.5 m/s;  
The purpose of the plough is to remove loose material from the return run of the belt.

#### NOTES Working temperatures of PU Rulmeca scrapers:

Max. temperature: + 50°C in wet environments.

Max. temperature: + 85°C in dry environments.

(ambient temperature + frictional heat).

#### Option for surface of steel parts:

Powder coat 60-80 µm

Coating with thermo plastic 120-800 µm







Stainless steel EN 1.4301 /AISI 304 / SS2333

#### Notes:

\* PU 91 can be used at belt speeds up to 5 m/s with certain modifications. Contact your Rulmeca representative.

\*\* PU 92 can be used at belt speeds up to 4.5 m/s with certain modifications. Contact your Rulmeca representative.

### 5.4.1 Scrapers with Polyurethane blades - Guide Table:

Scraper Code	Type	Blade	Position	BW mm	Max Speed m/s	Reversible Belt	Application	Shape
PU-83	Simple Pre-Scraper	PU Single	Tangential to pulley Ø220-1000	400-2000	3.5	✓	For easy to medium duty cleaning	
PU-29	Pre-Scraper	PU Single	Tangential to pulley Ø320-800 mm	400-1600	5,0	✓	For heavy duty cleaning	
PU-89	Heavy Pre-Scraper	PU Single-Thick	Tangential to pulley Ø400-1000	650-1600	6	✓	For heavy duty cleaning	
PU-91	Pre-Scraper with segment PU blades	PU Segments	Tangential to pulley Ø220-630	400-2000	3.5*	✓	Medium to heavy duty cleaning. Accurate cleaning due to flexible multi sectored blades	
PU-92	Secondary Scraper	PU Single-Thick	Under the return belt (300-100 mm from head pulley)	400-2000	3.5**	No	For medium duty with stringent cleaning requirements. Also in combination of a pre-scraper for a max cleaning effect	
PU-88	Plough Scraper	2 PU Strips at V	Over the return run of the belt (near tail pulley)	400-1800	4.5		To remove loose material from the return upper run of the belt	

**Notes:**

\* PU 91 can be used at belt speeds up to 5 m/s with certain modifications. Contact your Rulmeca representative.

\*\* PU 92 can be used at belt speeds up to 4.5 m/s with certain modifications. Contact your Rulmeca representative.

## 5 Belt Scrapers

### Simple Pre-Scraper with single PU blade series PU 83



#### 5.4.2 Scraper PU 83

The PU 83 pre-scraper truly symbolizes our aim of making simple, effective scrapers.

**Simplicity:** the scraper strip is easy to remove from the beam (without tools) for replacement and cleaning. Simple holders guarantee easy fitting and functionality. A lever arm that is fixed to the frame using a chain produces the required scraper pressure.

Made for pulleys  $\varnothing 220-1000$  mm

B-W 400-2000mm

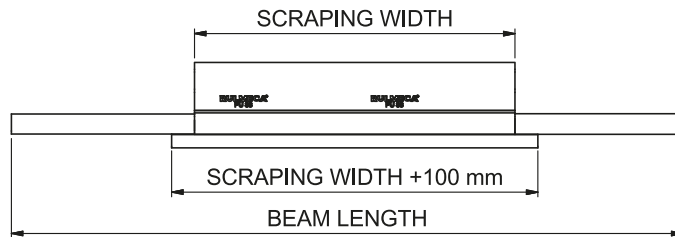
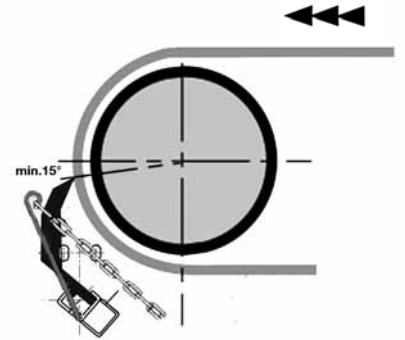

B-W	Scraping Width	Beam Length
400	350	1150
500	450	1250
650	550	1350
800	700	1500
1000	900	1700
1200	1050	1850
1400	1250	2050
1600	1450	2250
1800	1650	2450
2000	1850	2650

# Pre-Scraper with single PU blade series PU 29

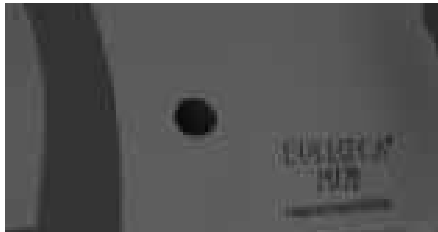
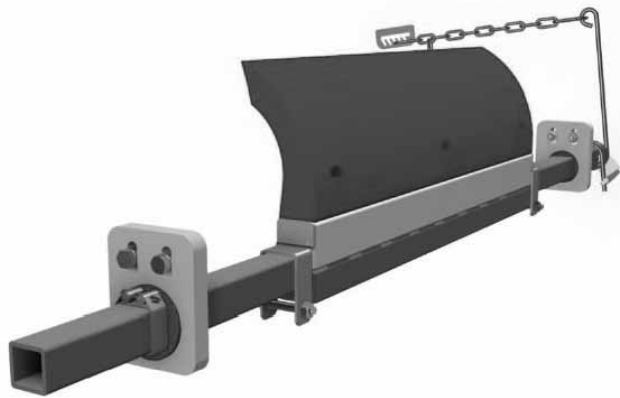

To quickly snap the blade out of the cassette, the holes in the blade can be used for leverage.

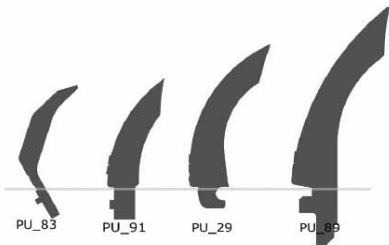

PU\_29 (third from the left) compared to PU\_83 and PU\_91 to the left and PU\_89 to the right.

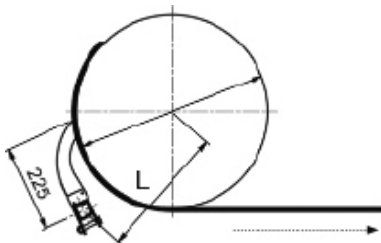

Drum pulley	L
ø320	289
ø400	313
ø500	350
ø630	405
ø800	480

Belt widths B-W 400-1600.  
Recommended for ø 320-800 mm pulleys.  
All steel parts are electro-galvanized as standard.  
From B-W 1000 the scraper is supplied with dual lever arms. From B-W 1600 the scraper is supplied with Holder HD.

## 5.4.3 PU 29 Series

PU\_29 pre-scraper is a large belt cleaner with a single scraper blade. The snap function to assemble the scraper blade is unique and its design is patented. It's unique spring lever ensures that the correct pressure is maintained against the belt which reduces maintenance time and prolongs the lifespan of the scraper and the conveyor belt.

The pre-scraper shall be positioned against the drive pulley right below the flow of material. Due to its larger blade and sturdier design, the PU\_29's belt cleaner withstands heavier operation and larger drums. Therefore, PU\_29 is easy to disassemble for maintaining the belt or cleaning the scraper.

1. Scraper blade, see art. no. below
2. Aluminum profile
3. Beam
4. Brackets LEFT-RIGHT
5. Holder H complete SPU\_8388/ SPU\_8388 HD
6. Lever arm complete SPU\_9178

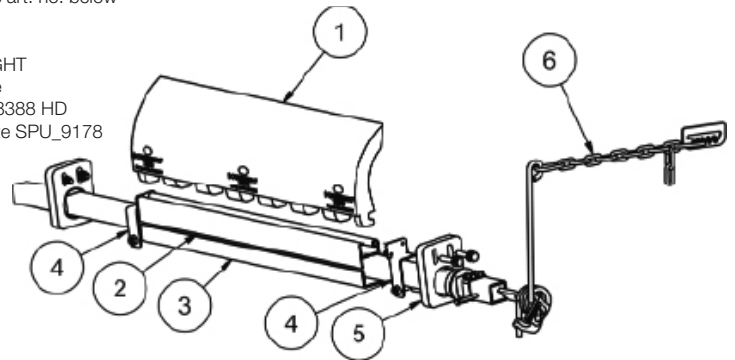

ART. NO.	B-W	Scraper width	Beam length	Qty. lever arms
<b>PU_29_400</b>	400	400	1100	1
<b>PU_29_500</b>	500	500	1200	1
<b>PU_29_600</b>	650	600	1300	1
<b>PU_29_800</b>	800	700	1500	1
<b>PU_29_1000</b>	1000	900	1700	2
<b>PU_29_1200</b>	1200	1100	1900	2
<b>PU_29_1400</b>	1400	1300	2100	2
<b>PU_29_1600</b>	1600	1500	2300	2

Wider belt cleaners can be offered on request.

## 5 Belt Scrapers

### Robust Pre-Scraper with single PU blade series PU 89

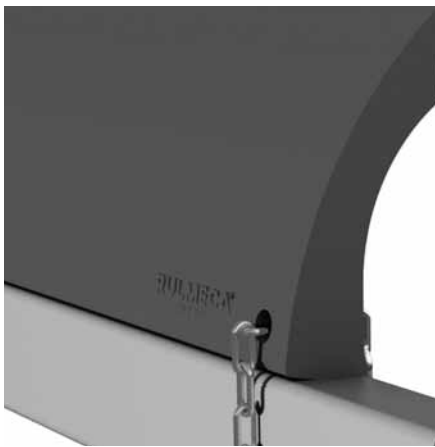
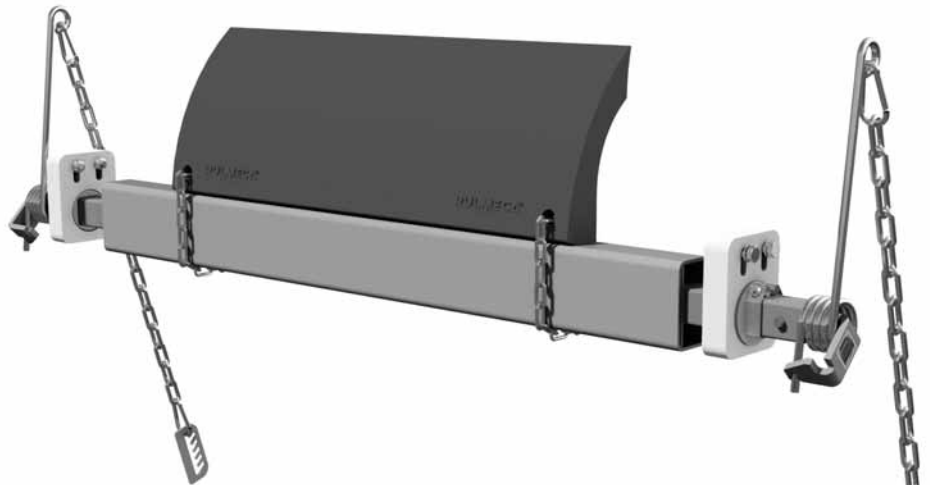

#### 5.4.4 Scraper PU 89

PU 89 is a robust pre-scraper that effectively cleans the conveyor belt in tough operating environments.

Made for pulleys  $\varnothing 400 - 1000$  mm.

The scraper blade is a solid polyurethane strip that adapts to the shape of the conveyor belt and pulley. Changing the blade is very easy and can be done without any tools. The scraper has been designed with a minimum of moving parts.

B-W 650-1600mm

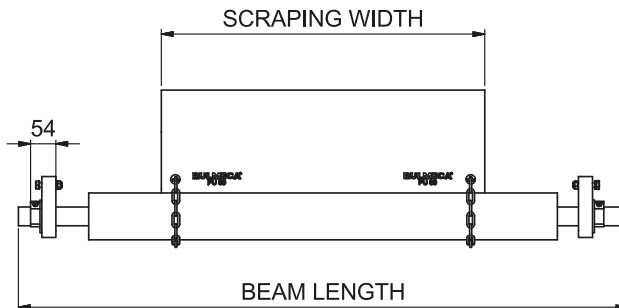
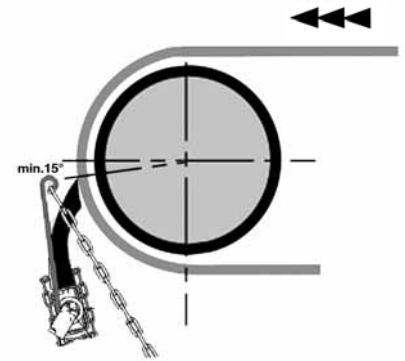

B-W	Scraping Width	Beam Length
650	545	850
800	695	1300
1000	895	1500
1200	1095	1700
1400	1295	1900
1600	1495	2100

# Pre-Scraper with separated flexible PU blades series PU 91

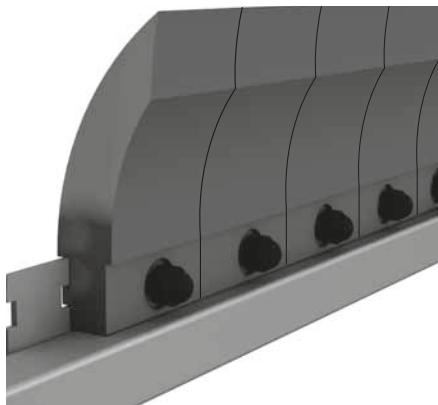
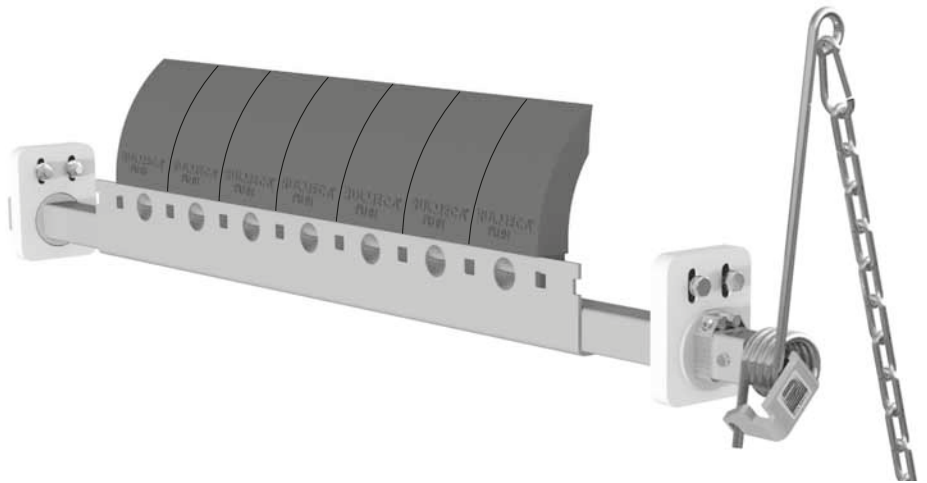

## 5.4.5 Scraper PU 91

The PU91 pre-scraper with scraper segments that flex individually. It is fitted at the front of the drive pulley, with the pu-blades just below the horizontal centre line of the pulley, at right angles to the conveyor belt.

Can be fitted with tungsten-carbide blades.

B-W 400-2000mm

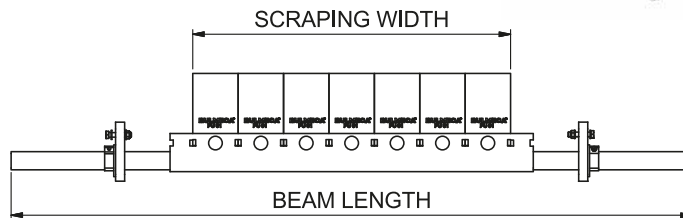
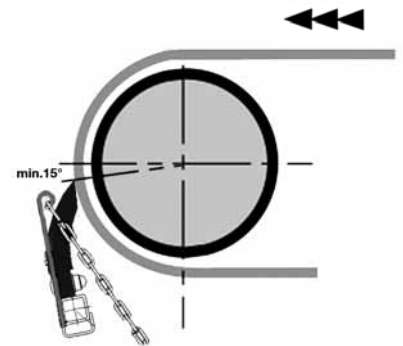

B-W	Segments	Scraping Width	Beam Length
400	4	400	1100
500	5	500	1200
650	6	600	1300
800	7	700	1500
1000	9	900	1700
1200	11	1100	1900
1400	13	1300	2100
1600	15	1500	2300
1800	17	1700	2500
2000	19	1900	2700

## 5 Belt Scrapers

### Secondary Scraper with single PU blade series **PU 92**

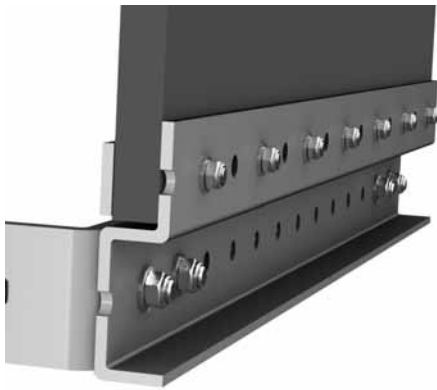

#### 5.4.6 Secondary Scraper PU 92

PU 92 secondary scraper is placed below the drive pulley. The pressure of the PU strip against the belt is produced by two pre tensioned torsion springs. The installation dimensions of the scraper can be continuously adjusted. The scraper cannot be used on belts with reversible operations.

Can be fitted with tungsten-carbide blades.

BW 400-2000

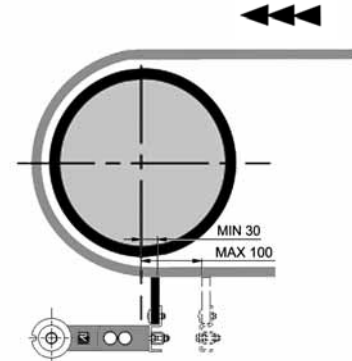
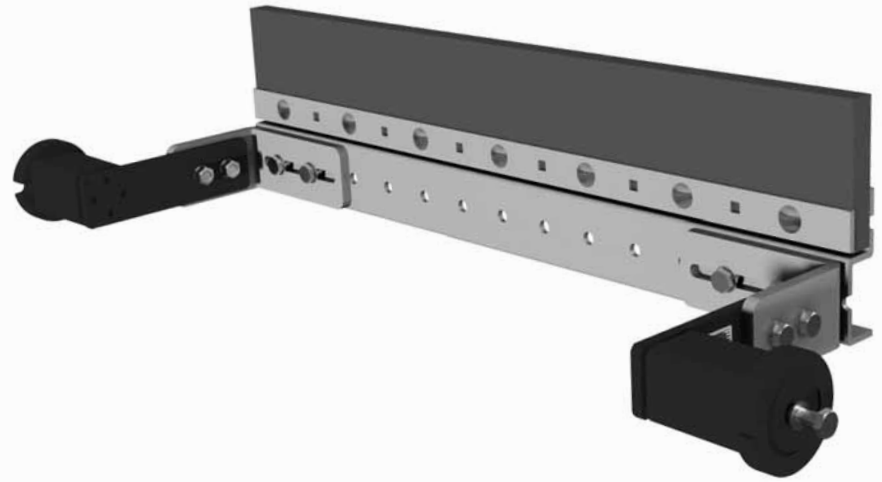
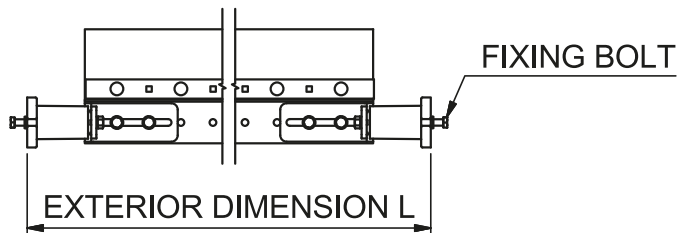

B-W	Scraping Width	L - Length
400	400	482 - 582
500	500	582 - 682
650	600	582 - 682
800	700	840 - 940
1000	900	1040 - 1140
1200	1100	1240 - 1340
1400	1200	1440 - 1540
1600	1400	1700 - 1800
1800	1600	1900 - 2000
2000	1800	2100 - 2200

# Plough Scraper

with a couple of PU blades  
series **PU 88**

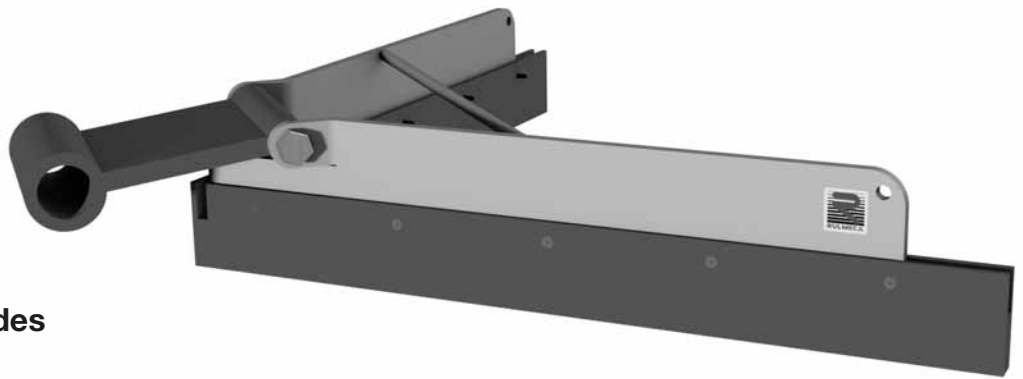

## 5.4.7 Plough Scraper PU 88

The PU 88 is a stable plough with steel frame and exchangeable pu-scraper strips. When fitting the plough, a tube of diameter 40 mm is inserted through the PU link. The tube is then fixed to the frame of the conveyor.

B-W 400-1800mm

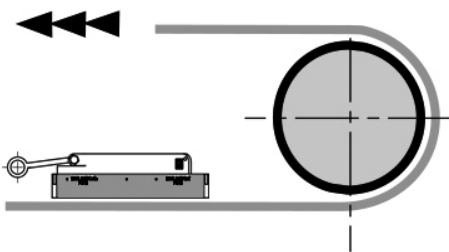
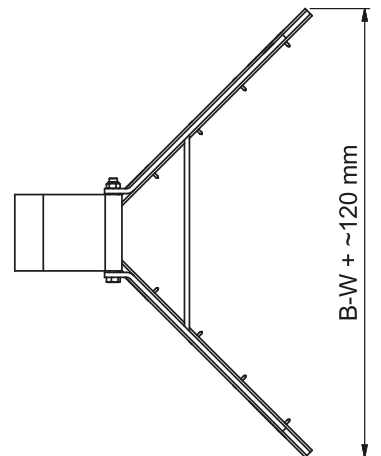
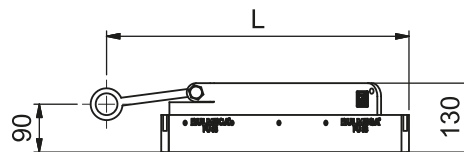

B-W	L
400	380
500	430
650	510
800	570
1000	680
1200	780
1400	880
1600	980
1800	1080

# 5 Belt Scrapers

## 5.4.8 Codes

**Type PU-83**  
Simple Pre-scraper with single polyurethane blade

**Type PU-29**  
Pre-scraper with single polyurethane blade

**Type PU-89**  
Heavy Pre- scraper with single polyurethane blade

**Type PU-91**  
Pre- scraper with segmented polyurethane blades

### PU Series - Polyurethane Scrapers

Article Code	Description
PU_83_400	Scraper PU-83 BW 400 SW = 350 single tensioning lever arm
PU_83_500	Scraper PU-83 BW 500 SW = 450 single tensioning lever arm
PU_83_650	Scraper PU-83 BW 650 SW = 550 single tensioning lever arm
PU_83_800	Scraper PU-83 BW 800 SW = 700 single tensioning lever arm
PU_83_1000	Scraper PU-83 BW 1000 SW = 900 double tensioning lever arm
PU_83_1200	Scraper PU-83 BW 1200 SW = 1050 double tensioning lever arm
PU_83_1400	Scraper PU-83 BW 1400 SW = 1250 double tensioning lever arm
PU_83_1600	Scraper PU-83 BW 1600 SW = 1450 double tensioning lever arm
PU_83_1800	Scraper PU-83 BW 1800 SW = 1650 double tensioning lever arm
PU_83_2000	Scraper PU-83 BW 2000 SW = 1850 double tensioning lever arm
PU_29_400	Scraper PU-29 BW 400 SW = 400 single tensioning lever arm
PU_29_500	Scraper PU-29 BW 500 SW = 500 single tensioning lever arm
PU_29_650	Scraper PU-29 BW 650 SW = 600 single tensioning lever arm
PU_29_800	Scraper PU-29 BW 800 SW = 700 single tensioning lever arm
PU_29_1000	Scraper PU-29 BW 1000 SW = 900 double tensioning lever arm
PU_29_1200	Scraper PU-29 BW 1200 SW = 1100 double tensioning lever arm
PU_29_1400	Scraper PU-29 BW 1400 SW = 1300 double tensioning lever arm
PU_29_1600	Scraper PU-29 BW 1600 SW = 1500 double tensioning lever arm
PU_89_650	Scraper PU-89 BW 650 SW = 545
PU_89_800	Scraper PU-89 BW 800 SW = 695
PU_89_1000	Scraper PU-89 BW 1000 SW = 895
PU_89_1200	Scraper PU-89 BW 1200 SW = 1095
PU_89_1400	Scraper PU-89 BW 1400 SW = 1295
PU_89_1600	Scraper PU-89 BW 1600 SW = 1495
PU_91_400	Scraper PU-91 BW 400 SW = 400 single tensioning lever arm
PU_91_500	Scraper PU-91 BW 500 SW = 500 single tensioning lever arm
PU_91_650	Scraper PU-91 BW 650 SW = 600 single tensioning lever arm
PU_91_800	Scraper PU-91 BW 800 SW = 700 single tensioning lever arm
PU_91_1000	Scraper PU-91 BW 1000 SW = 900 double tensioning lever arm
PU_91_1200	Scraper PU-91 BW 1200 SW = 1100 double tensioning lever arm
PU_91_1400	Scraper PU-91 BW 1400 SW = 1300 double tensioning lever arm
PU_91_1600	Scraper PU-91 BW 1600 SW = 1500 double tensioning lever arm
PU_91_1800	Scraper PU-91 BW 1800 SW = 1700 double tensioning lever arm
PU_91_2000	Scraper PU-91 BW 2000 SW = 1900 double tensioning lever arm
PU_91_2200	Scraper PU-91 BW 2200 SW = 2100 double tensioning lever arm
PU_91_2400	Scraper PU-91 BW 2400 SW = 2300 double tensioning lever arm

**Type PU-92**  
Secondary scraper with single polyurethane blade

Article Code	Description
<b>PU_92_400</b>	Secondary scraper PU-92 BW 400 SW = 400
<b>PU_92_500</b>	Secondary scraper PU-92 BW 500 SW = 500
<b>PU_92_650</b>	Secondary scraper PU-92 BW 650 SW = 600
<b>PU_92_800</b>	Secondary scraper PU-92 BW 800 SW = 700
<b>PU_92_1000</b>	Secondary scraper PU-92 BW 1000 SW = 900
<b>PU_92_1200</b>	Secondary scraper PU-92 BW 1200 SW = 1100
<b>PU_92_1400</b>	Secondary scraper PU-92 BW 1400 SW = 1300
<b>PU_92_1600</b>	Secondary scraper PU-92 BW 1600 SW = 1500

**Type PU-88**  
Plough scraper - V form PU blades

<b>PU_88_400</b>	Plough scraper PU-88 BW 400
<b>PU_88_500</b>	Plough scraper PU-88 BW 500
<b>PU_88_650</b>	Plough scraper PU-88 BW 650
<b>PU_88_800</b>	Plough scraper PU-88 BW 800
<b>PU_88_1000</b>	Plough scraper PU-88 BW 1000
<b>PU_88_1200</b>	Plough scraper PU-88 BW 1200
<b>PU_88_1400</b>	Plough scraper PU-88 BW 1400
<b>PU_88_1600</b>	Plough scraper PU-88 BW 1600

# 5 Belt Scrapers

## 5.4.9 Codes

**Ref. PU-83**  
Simple Pre-scraper with single polyurethane blade

**Ref. PU-29**  
Pre-scraper with single polyurethane blade

**Ref. PU-89**  
Heavy Pre- scraper with single polyurethane blade

**Ref. PU-91**  
Pre- scraper with segmented polyurethane blades

**Ref. PU-92**  
Secondary scraper with single polyurethane blade

**Ref. PU-88**  
Plough scraper sets of PU V blades

### SPU Spare Parts & Accessories - PU Series Scrapers

Article Code	Description
<b>SPU_8324</b>	Polyurethane blades SPU 8324 SW = 350 for scrapers PU 83 BW 400
<b>SPU_8325</b>	Polyurethane blades SPU 8325 SW = 450 for scrapers PU 83 BW 500
<b>SPU_8326</b>	Polyurethane blades SPU 8326 SW = 550 for scrapers PU 83 BW 650
<b>SPU_8328</b>	Polyurethane blades SPU 8328 SW = 700 for scrapers PU 83 BW 800
<b>SPU_8330</b>	Polyurethane blades SPU 8330 SW = 900 for scrapers PU 83 BW 1000
<b>SPU_8332</b>	Polyurethane blades SPU 8332 SW = 1050 for scrapers PU 83 BW 1200
<b>SPU_8334</b>	Polyurethane blades SPU 8334 SW = 1250 for scrapers PU 83 BW 1400
<b>SPU_8336</b>	Polyurethane blades SPU 8336 SW = 1450 for scrapers PU 83 BW 1600
<b>SPU_8338</b>	Polyurethane blades SPU 8338 SW = 1650 for scrapers PU 83 BW 1800
<b>SPU_8340</b>	Polyurethane blades SPU 8340 SW = 1850 for scrapers PU 83 BW 2000
<b>SPU_2924</b>	Polyurethane blades SPU 2924 SW = 400 for scrapers PU 29 BW 400
<b>SPU_2925</b>	Polyurethane blades SPU 2925 SW = 500 for scrapers PU 29 BW 500
<b>SPU_2926</b>	Polyurethane blades SPU 2926 SW = 600 for scrapers PU 29 BW 650
<b>SPU_2928</b>	Polyurethane blades SPU 2928 SW = 700 for scrapers PU 29 BW 800
<b>SPU_2930</b>	Polyurethane blades SPU 2930 SW = 900 for scrapers PU 29 BW 1000
<b>SPU_2932</b>	Polyurethane blades SPU 2932 SW = 1100 for scrapers PU 29 BW 1200
<b>SPU_2934</b>	Polyurethane blades SPU 2934 SW = 1300 for scrapers PU 29 BW 1400
<b>SPU_2936</b>	Polyurethane blades SPU 2936 SW = 1500 for scrapers PU 29 BW 1600
<b>SPU_8926</b>	Polyurethane blades SPU 8926 SW = 545 for scrapers PU 89 BW 650
<b>SPU_8928</b>	Polyurethane blades SPU 8928 SW = 695 for scrapers PU 89 BW 800
<b>SPU_8930</b>	Polyurethane blades SPU 8930 SW = 895 for scrapers PU 89 BW 1000
<b>SPU_8932</b>	Polyurethane blades SPU 8932 SW = 1095 for scrapers PU 89 BW 1200
<b>SPU_8934</b>	Polyurethane blades SPU 8934 SW = 1295 for scrapers PU 89 BW 1400
<b>SPU_8936</b>	Polyurethane blades SPU 8936 SW = 1495 for scrapers PU 89 BW 1600
<b>SPU_9100</b>	Blade segment in Polyurethane SPU 9100 for scrapers PU 91
<b>SPU_9224</b>	Polyurethane blades SPU 9224 SW = 400 for scrapers PU 92 BW 400
<b>SPU_9225</b>	Polyurethane blades SPU 9225 SW = 500 for scrapers PU 92 BW 500
<b>SPU_9226</b>	Polyurethane blades SPU 9226 SW = 600 for scrapers PU 92 BW 650
<b>SPU_9228</b>	Polyurethane blades SPU 9228 SW = 700 for scrapers PU 92 BW 800
<b>SPU_9230</b>	Polyurethane blades SPU 9230 SW = 900 for scrapers PU 92 BW 1000
<b>SPU_9232</b>	Polyurethane blades SPU 9232 SW = 1100 for scrapers PU 92 BW 1200
<b>SPU_9234</b>	Polyurethane blades SPU 9234 SW = 1300 for scrapers PU 92 BW 1400
<b>SPU_9236</b>	Polyurethane blades SPU 9236 SW = 1500 for scrapers PU 92 BW 1600
<b>SPU_9238</b>	Polyurethane blades SPU 9238 SW = 1700 for scrapers PU 92 BW 1800
<b>SPU_9240</b>	Polyurethane blades SPU 9240 SW = 1900 for scrapers PU 92 BW 2000
<b>SPU_8824</b>	Set of Polyurethane blades SPU 8824 L1 = 350 L2 = 370 for plough scrapers PU 88 BW 400
<b>SPU_8825</b>	Set of Polyurethane blades SPU 8825 L1 = 420 L2 = 440 for plough scrapers PU 88 BW 500
<b>SPU_8826</b>	Set of Polyurethane blades SPU 8826 L1 = 540 L2 = 560 for plough scrapers PU 88 BW 650
<b>SPU_8828</b>	Set of Polyurethane blades SPU 8828 L1 = 630 L2 = 650 for plough scrapers PU 88 BW 800
<b>SPU_8830</b>	Set of Polyurethane blades SPU 8830 L1 = 780 L2 = 800 for plough scrapers PU 88 BW 1000
<b>SPU_8832</b>	Set of Polyurethane blades SPU 8832 L1 = 920 L2 = 940 for plough scrapers PU 88 BW 1200
<b>SPU_8834</b>	Set of Polyurethane blades SPU 8834 L1 = 1060 L2 = 1080 for plough scrapers PU 88 BW 1400
<b>SPU_8836</b>	Set of Polyurethane blades SPU 8836 L1 = 1230 L2 = 1250 for plough scrapers PU 88 BW 1600