



2.5.4 - Rollers series MPS

In recent years there has been a substantial increase in the use of belt conveyors due to their recognition as the most economic form of bulk transport.

The rollers comprise the principal components and are the focus of attention of the designer and the user who are always validating products both from a technical and economic point of view.



Accepting this premise, Rulmeca, with the intention to satisfy various requirements in the best way, has developed rollers series MPS, that complement the very heavy roller series PSV.



Where used

The use of this roller series is particularly advantageous in the economic sense. MPS uses rigid radial precision ball bearings.

It is used in medium duty conveyors, but also at high speeds and even in dirty external environment.

The working temperature is defined as between -20°C and $+100^{\circ}\text{C}$.





2 Rollers

series
MPS



Characteristics

Rulmeca, in designing these rollers combines the requirements of high quality and hermetic sealing with low cost and where the loading does not require spindles of $\varnothing 20$ mm.

Roller shell

Consists of a selected steel tube, machined at either end to strict tolerances.

Bearing housing

Formed from strip steel deep pressed and calibrated to ISO M7: this tolerance allowing a perfect match between the bearing and the relevant parts of the sealing.

Unibloc

The roller shell and the two bearing housings are welded together in a way that forms a monolithic structure of exceptional strength. This method guarantees the maximum precision and the minimum out of balance forces in the rollers.

Spindle

The bright drawn precision spindle of $\varnothing 15$ provides an ideal fit to the bearing resulting in its perfect rotation.

The standard design utilises closing bushes, pre-machined with spanner flats $ch = 17$ and 14 .

Bearings

MPS series rollers use rigid radial 6202 series precision ball bearings from the very best market sources.

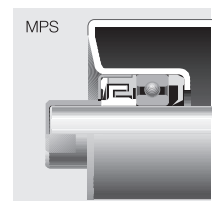

Sealing

The external seal is a cover cap in zinc plated steel complete with a wiper seal.

Internally, the sealing comprises a nylon (PA6) labyrinth seal with optimum resistance to chemicals and to mechanical pressure, filled with grease that protects the bearing from unwelcome ingress of external particles.

A lip seal is positioned on the inside of the bearing that wipes the spindle and creates an ample space for grease. Its design is such as to contain lubrication even in the case of extreme changes in temperature and to protect the bearing from condensation and possible rusting from the inside of the roller tube.

Lubrication

The grease used is a special lithium based grease with high resistance to ageing and humidity.

The quantity introduced into the roller is sufficient to guarantee an optimum lubrication of the bearing for the working life of the roller.

Balancing

The optimum roller balance is obtained thanks to the auto centring of the bearing housings to the tube (as in series PSV) during the automatic welding process.

This balance allows the MPS rollers to be used at high speeds eliminating dangerous vibrations and the subsequent "hammering" of the bearings.

Final Testing

At the end of the automatic assembly line 100% of the rollers are subjected to high speed rotation, that promotes the even distribution of grease in the seals, and verifies the rotation resistance. Any roller failing pre-set criteria is automatically eliminated from the production line.

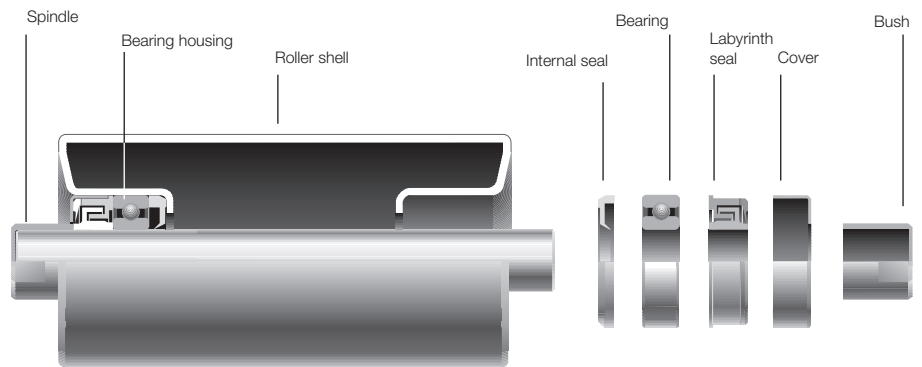

Rollers certified according to ATEX 94/9/EC norms,
Explosion Group I category M2 for Mines,
Explosion Group II category 2G for gas and 2D for dust,
Explosion Group II category 3G for gas and 3D for dust
(Zones 1, 2 for gas, Zones 21, 22 for dust).

The table indicates the roller diameters in production. Upon request non standard dimensions may be supplied and with flats $ch = 14$ mm.

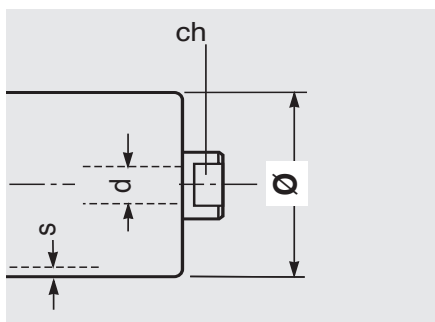

Programme of production series MPS

roller type	Ø mm	basic design	s	spindle		bearing	note
				d	ch		
MPS 1	50	N	3	15	17	6202	with tube and spindle in steel S235JR (EN 10027-1) ex Fe360 (EN 10025) St37 (DIN 17100)
	60	N	3				
	76	N	3				
	89	N	3				
	102	N	3				



2 Rollers

series
MPS 1

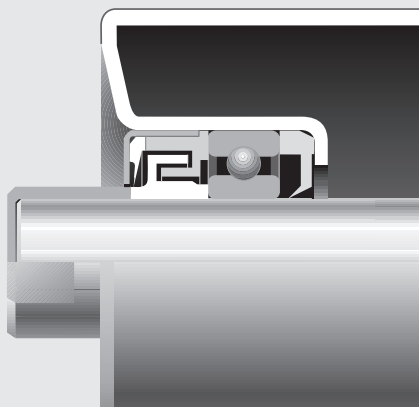

Section through seal

Ø 50 N

Bearing 6202
(15 x 35 x 11)

d = 15
d₁ = 20
ch = 17 *
s = 3
e = 4
g = 9

*ch = 14 upon
request

Example of ordering
standard design
MPS1,15B,50N,208

for special design
see pages 80-81

belt width mm	roller dimensions mm			weight Kg		load capacity daN					
	arrangements 			rotating parts	total	belt speed m/s					
	B	C	A			0.5	0.75	1	1.25	1.5	1.75
400	160	168	186	0.8	1.1	138	121	110	102	96	91
300 500	200	208	226	1.0	1.3	138	121	110	102	96	91
400 650	250	258	276	1.1	1.5	138	121	110	102	96	91
500 800	315	323	341	1.4	1.8	138	121	110	102	96	91
300 650 1000	380	388	406	1.6	2.1	138	121	110	102	96	91
800	465	473	491	1.9	2.6	117	117	110	102	96	91
400	500	508	526	2.0	2.7	109	109	109	102	96	91
500 1000	600	608	626	2.4	3.2	91	91	91	91	91	91
650	750	758	776	2.9	3.9	73	73	73	73	73	73
800	950	958	976	3.6	4.9	58	58	58	58	58	58
1000	1150	1158	1176	4.3	5.9	49	49	49	49	49	49

The indicated load capacity relates to a project working of 10,000 hours.

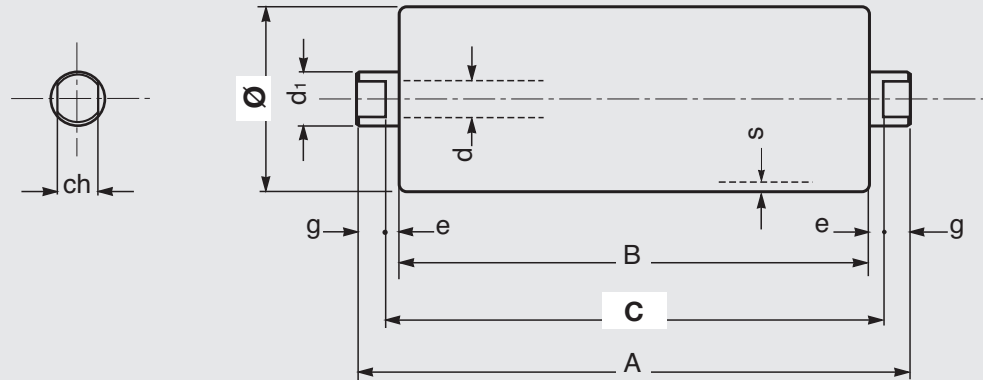

Ø 60 N

Bearing 6202
(15 x 35 x 11)

d = 15
d₁ = 20
ch = 17 *
s = 3
e = 4
g = 9

*ch = 14 upon
request

belt	roller					weight		load capacity					
	width mm			dimensions mm		Kg		daN					
arrangements 	B	C	A	rotating		belt speed m/s							
				parts	total	0.75	1	1.25	1.5	1.75	2		
400	160	168	186	1.0	1.2	128	117	108	102	97	93		
300 500	200	208	226	1.1	1.5	128	117	108	102	97	93		
400 650	250	258	276	1.4	1.7	128	117	108	102	97	93		
500 800	315	323	341	1.6	2.1	128	117	108	102	97	93		
300 650 1000	380	388	406	1.9	2.5	128	117	108	102	97	93		
800	465	473	491	2.3	2.9	114	114	108	102	97	93		
400	500	508	526	2.4	3.1	106	106	106	102	97	93		
500 1000	600	608	626	2.8	3.7	88	88	88	88	88	88		
650	750	758	776	3.5	4.5	70	70	70	70	70	70		
800	950	958	976	4.3	5.7	55	55	55	55	55	55		
1000	1150	1158	1176	5.2	6.8	46	46	46	46	46	46		

The indicated load capacity relates to a project working of 10,000 hours.

Example of ordering
standard design
MPS1,15B,60N,258

for special design
see pages 80-81



2 Rollers

series MPS 1

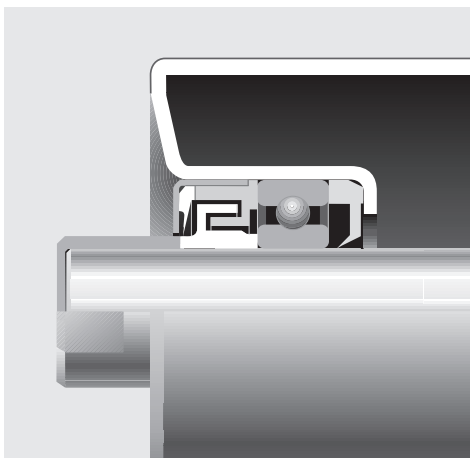

Section through seal

Ø 76 N

Bearing 6202
(15 x 35 x 11)

d = 15
d₁ = 20
ch = 17 *
s = 3
e = 4
g = 9

*ch = 14 upon request

Example of ordering
standard design
MPS1,15B,76N,323

for special design
see pages 80-81

belt		roller										
width mm		dimensions mm			weight Kg		load capacity daN					
arrangements		B	C	A	rotating parts		belt speed m/s					
					parts	total	1	1.25	1.5	1.75	2	2.5
400		160	168	186	1.2	1.5	126	117	110	105	100	93
300	500	200	208	226	1.4	1.8	126	117	110	105	100	93
400	650	250	258	276	1.7	2.1	126	117	110	105	100	93
500	800	315	323	341	2.1	2.5	126	117	110	105	100	93
300	650 1000	380	388	406	2.4	3.0	126	117	110	105	100	93
	800	465	473	491	2.9	3.6	113	113	110	105	100	93
400		500	508	526	3.1	3.8	104	104	104	104	100	93
500	1000	600	608	626	3.6	4.5	86	86	86	86	86	86
650		750	758	776	4.4	5.5	68	68	68	68	68	68
800		950	958	976	5.5	6.8	53	53	53	53	53	53
1000		1150	1158	1176	6.6	8.2	44	44	44	44	44	44

The indicated load capacity relates to a project working of 10,000 hours.

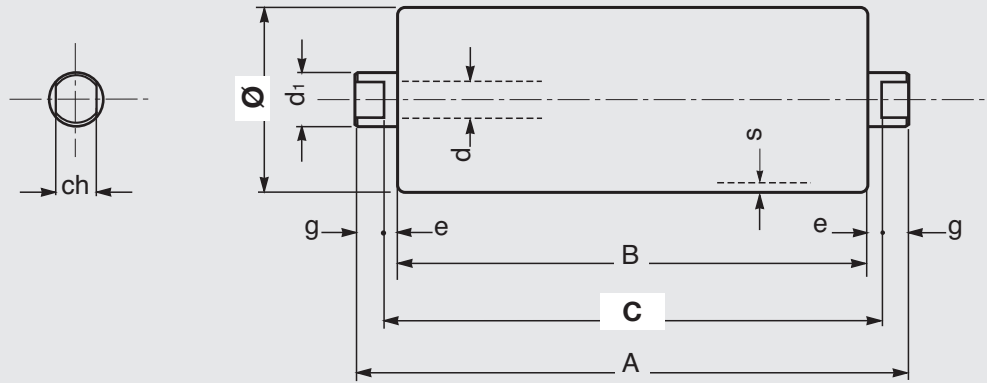

Ø 89 N

Bearing 6202
(15 x 35 x 11)

d = 15
d₁ = 20
ch = 17 *
s = 3
e = 4
g = 9

*ch = 14 upon
request

belt	roller			weight		load capacity					
	width mm	dimensions mm			Kg		daN				
arrangements 	B	C	A	rotating		belt speed m/s					
				parts	total	1	1.25	1.5	2	2.5	3
400	160	168	186	1.4	1.7	133	124	116	106	98	92
300 500	200	208	226	1.7	2.0	133	124	116	106	98	92
400 650	250	258	276	2.0	2.4	133	124	116	106	98	92
500 800	315	323	341	2.4	2.9	133	124	116	106	98	92
300 650 1000	380	388	406	2.9	3.4	133	124	116	106	98	92
800 1200	465	473	491	3.4	4.1	112	112	112	106	98	92
400	500	508	526	3.6	4.3	103	103	103	103	98	92
500 1000	600	608	626	4.3	5.1	85	85	85	85	85	85
1200	700	708	726	4.9	5.9	72	72	72	72	72	72
650	750	758	776	5.2	6.3	67	67	67	67	67	67
800	950	958	976	6.5	7.9	53	53	53	53	53	53
1000	1150	1158	1176	7.8	9.4	43	43	43	43	43	43
1200	1400	1408	1426	9.4	11.4	35	35	35	35	35	35

The indicated load capacity relates to a project working of 10,000 hours.

Example of ordering
standard design
MPS1,15B,89N,758

for special design
see pages 80-81



2 Rollers

series MPS 1

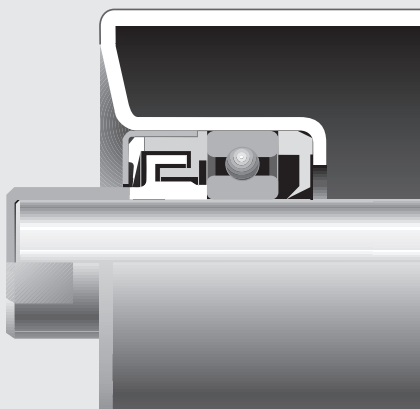

Section through seal

Ø 102 N

Bearing 6202
(15 x 35 x 11)

d = 15
d₁ = 20
ch = 17 *
s = 3
e = 4
g = 9

*ch = 14 upon
request

Example of ordering
standard design
MPS1,15B,102N,388

for special design
see pages 80-81

belt		roller									
width mm	dimensions mm	weight Kg		load capacity daN							
arrangements 	B	C	A	rotating		belt speed m/s					
				parts	total	1	1.25	1.5	2	2,5	3
400	160	168	186	1.7	1.9	139	129	122	111	103	97
300 500	200	208	226	2.0	2.3	139	129	122	111	103	97
400 650	250	258	276	2.3	2.7	139	129	122	111	103	97
500 800	315	323	341	2.8	3.3	139	129	122	111	103	97
300 650 1000	380	388	406	3.3	3.9	139	129	122	111	103	97
800 1200	465	473	491	3.9	4.6	112	112	112	111	103	97
400	500	508	526	4.2	4.9	103	103	103	103	103	97
500 1000	600	608	626	4.9	5.8	85	85	85	85	85	85
1200	700	708	726	5.6	6.6	72	72	72	72	72	72
650	750	758	776	6.0	7.1	67	67	67	67	67	67
800	950	958	976	7.5	8.8	52	52	52	52	52	52
1000	1150	1158	1176	8.9	10.6	43	43	43	43	43	43
1200	1400	1408	1426	10.8	12.7	35	35	35	35	35	35

The indicated load capacity relates to a project working of 10,000 hours.

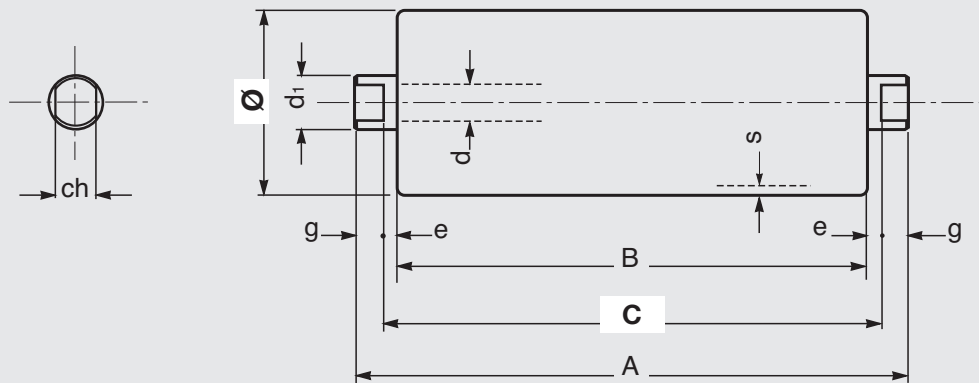



2 Rollers